

**ETHNOGRAPHY AND ARCHAEOLOGY ON THE NORTH COAST  
OF NEW SOUTH WALES.**

**LUKE GODWIN**  
Prehistory & Archaeology  
University of New England

and

**HOWARD CREAMER**  
New South Wales  
National Parks and Wildlife Service

**INTRODUCTION**

A number of recent anthropological studies have noted that even in situations that are far removed from the "traditional" pre-European lifestyle, including the urban context, Aborigines employ distinctively Aboriginal methods of resolving crises and problems encountered (see Langton 1981 for examples). Quite often the solution has a strong basis in some element of "traditional" culture, such as the use of kinship systems in confronting a shortage of housing in Adelaide (Gale 1977). Another example of this distinctive Aboriginal culture, which Langton (1981) has cogently argued as being much more than a culture of poverty, can be seen in the very strong retention of "traditional" values and beliefs by Aborigines living a "non-traditional" lifestyle. Chase (1981:25) provides a clear case of this when describing the detailed knowledge of clan territories in tribal areas retained by the older people living on the Lockhart Aboriginal Reserve on Cape York, even though in some cases these people have not visited these particular areas for many years.

A similar case can be made for parts of New South Wales, and in particular the north-eastern quarter. Contrary to numerous assertions (Radcliffe-Brown 1929:408, McBryde 1978:3, Lampert 1981:71), there still exists a vital knowledge of "sites of significance" amongst Aborigines in this area, as exemplified by the results of the Aboriginal Sites of Significance Survey conducted in New South Wales over the past 10 years (Creamer 1975, Kelly 1979). This survey has recorded over 500 sites in New South Wales significant to present-day Aborigines, a large proportion of them being mythological and ceremonial sites (Kelly 1979:82).

In this paper we present a case study from the N.S.W. north coast which emphasizes this preservation of "traditional" knowledge among Aborigines in this region. In doing this, we also draw parallels between this data and that from situations where Aborigines are generally believed to be living a fairly traditional lifestyle - namely, parts of central and northern Australia. What emerges is that there are a number of points of similarity between some Aborigines of the N.S.W. north coast and those of central and northern Australia, in terms of how they view their environment and choose to exploit it. We then examine the ethnoarchaeological implications of this case, as well as detailing some more general conclusions that arise from this study.

## ETHNOGRAPHY

The data presented in this paper were collected over a period of 10 days in April 1982. An archaeological survey of an area of 5km<sup>2</sup> and social anthropological study was undertaken as a preliminary reconnaissance near Yamba on the north coast of N.S.W. The survey had two aspects: first, to locate and assess archaeological sites in the area, and ascertain Aboriginal wishes concerning such sites, and second, to collect information on current Aboriginal land use and environmental perceptions.

The survey proceeded with an archaeologist and anthropologist pursuing different, yet related lines of inquiry. Reconnaissance of the area was carried out, concentrating on areas which offered archaeological visibility and where sites had already been reported. Liaison with local Aboriginal people was crucial to the archaeology, as well as the ethnography. Central to the anthropological method, which included collecting genealogical and census information, was the mapping of the cultural landscape of the Yaygir people, using as far as possible their own concepts of land and place. Our main consultants were Alan Laurie (60) who lives at the Pippi Beach Aboriginal Reserve, and his brother's daughter Patricia Laurie, who lives in the town of Yamba.

From the fieldwork it emerged that five main categories of "sites of significance" (with 23 examples) could be determined in the Yamba locale. These sites can be listed under the following headings:

1. Good Food Places
2. Recent Camping Places
3. Dangerous Places
4. Mythological Places
5. Ancestral Camping Places

Good Food Places. By far the most abundant sites significant to local Aborigines were the Good Food Places and Recent Camping Places, the total of which accounted for 15 of the 23 sites. We were impressed by how much the local Aborigines knew about locally-available "traditional" foods. These can be defined as being those components of their diet which were hunted, fished and collected before the major alteration of diet that took place through the introduction of tea, sugar and flour, after white settlement in the area. The following is a list of the main foods mentioned (there are probably others):

Aquatic: mullet, bream, flathead, flounder, whiting, jewfish, tailor, swallow tail, cobra worms, pipis, oysters, crabs, swans' eggs and beach worms (for bait).

Terrestrial: kangaroos and wallabies, carpet snake, yams and cunjevoi (mainly for the treatment of sores).

Good Food Places refer to spots from which good supplies of fish, yams, birds' eggs etc. can be obtained. The Yamba people collect shellfish, but not generally from a limited number of localities. Pipis can be collected along the surf beaches, particularly after storms, and estuarine species can be collected from most places in the lagoon and river channels. Only the rocky platform species are localised in their distribution, being confined to the few outcrops found along the beaches.

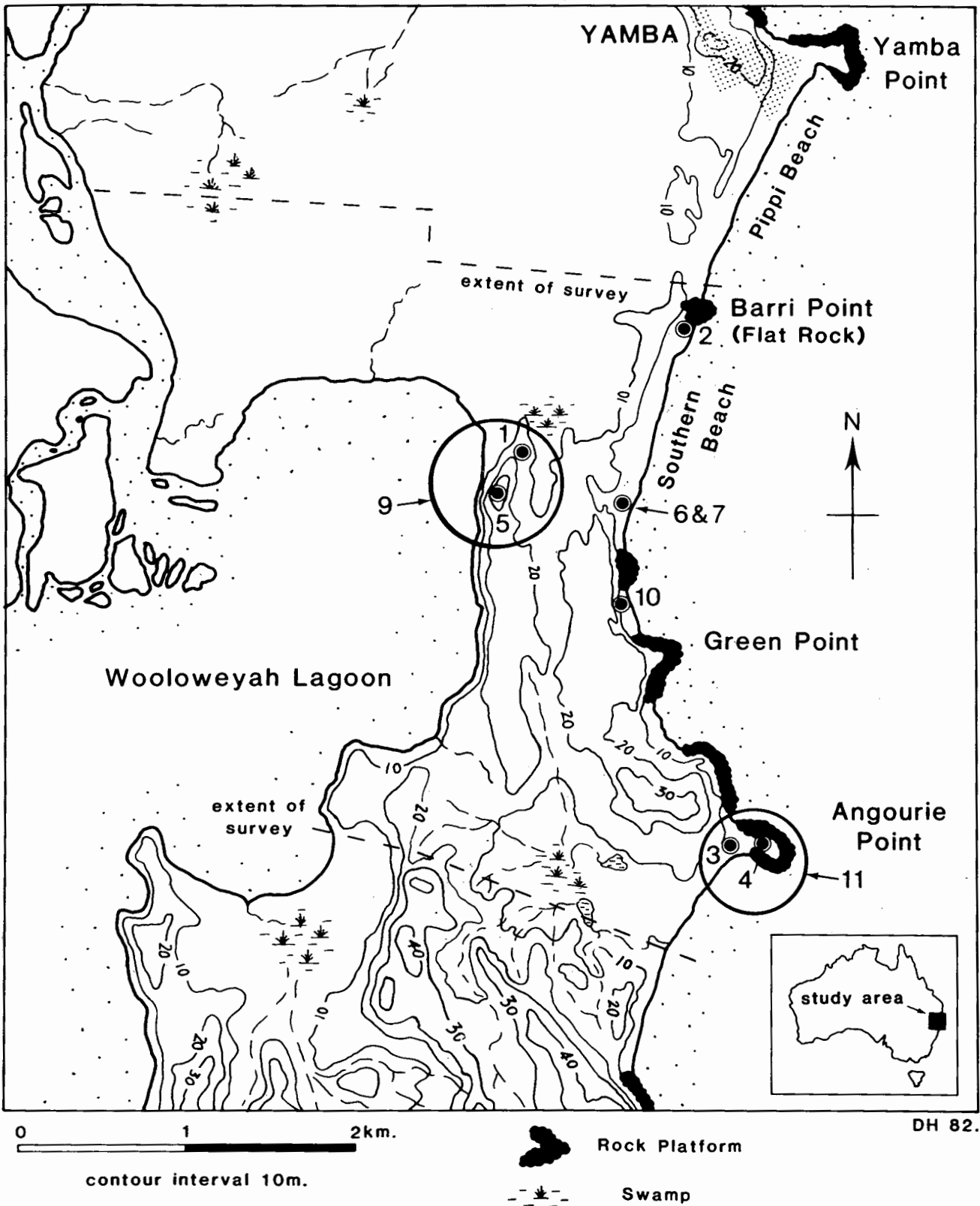

Figure 1. Map of the survey area, showing location of sites mentioned in text. Numbers refer to sites listed in Table 1.

Recent Camping Places consisted of two kinds. First, are those associated with the location of Aboriginal missions and reserves in the area over the past 100 years. There are four of these, including the present one at Pippi Beach Aboriginal reserve. Second, are those associated with getting away from town. This second type is quite often related to food-getting places, serving as a base for such activities.

Dangerous Places are identified as being where there has been a manifestation of a spirit, or where such a manifestation might occur. Usually it involved a person being physically harassed by a spirit, often by stoning them. Two of five such places were Bora initiation grounds. Similar types of sites have been recorded in the Northern Territory (Biernoff 1978).

Mythological Sites are identified by the presence of a feature central to a myth or that is explained by a myth. Mountains, rocks and swamps etc. may be mythological places. There are two sites of this type in the general area, one of which is the only reported site of significance to local Aboriginal people in this area prior to this survey.

Ancestral Camping Places can be, but not always, identified by spirit harassment. The illegal removal of top soil from a midden in the area led to both the site's discovery, and subsequent recognition of it as an ancestral camping place by local Aborigines. This case well illustrates feedback of archaeological information into the fast-growing Aboriginal appreciation of their prehistoric past. Only one site of this type occurred in the general area.

There are five Good Food Places (one of them a natural spring), one Recent Camping Place and one Mythological Site in the ca. 5km<sup>2</sup> survey area (see Table 1).

## ARCHAEOLOGY

Before this particular survey a total of four archaeological sites were known for the area. Four others were recorded during the survey, only two of which were within the specific survey area. We can state quite confidently that none of these sites were found only because of direct Aboriginal knowledge of their location. Indeed, they only knew of two archaeological sites in the survey area.

All of the archaeological sites were shell middens. They varied in size, vertically and horizontally, from scatters covering a few metres to stratified middens 30cm deep and covering ca. 20,000m<sup>2</sup>. The sites were located in three environmental settings: near Wooloweyah Lagoon (2 sites), on dunes behind the beach (2 sites), and on or just behind rocky platforms (2 sites). One site, Stockyard midden, is very large, covering an area of ca 200m x 100m. Its deposit consisted of shell 20cm to 30cm thick. It contains mainly estuarine shellfish species, particularly mud-whelks, oysters and cockles. The stratigraphic and geomorphic similarities between this and the Wombah middens, a few kilometres north on the other side of the Clarence River suggest it may be of a similar antiquity (i.e. from 4,000 B.P. to 1,000 B.P.) (McBryde 1976). The Stockyard midden contains backed blades in its upper units (observed in the section of the deposit exposed by illegal top soil removal). It contains other stone artefacts as well, including unifacial pebble choppers and stone imported from elsewhere.

Another site is known as the Barri Point midden. It is a rare example of a coastal midden in northern N.S.W. because: it contains stone artefacts; the shellfish species are drawn from three different environmental settings (rocky platform, coastal beach and estuarine); it is located on a dune just behind the rocky platform; and it has stratified deposit. Coastal middens are generally lenses of pipi shell located along open beaches and they usually do not possess evidence of stone working activities. The Barri Point midden contains bone (from mutton birds and macropods), and this is also unusual as most coastal middens do not.

The other middens are less impressive, partly because they have been badly disturbed by sand mining and other development. Some of them would have been quite substantial, extending over at least 30m x 20m and apparently having some stratified deposit, as well as stone artefacts.

TABLE 1. Features of the Yaygir cultural landscape. Middens, Good Food Places and Camping Places in the survey area (ca. 5km<sup>2</sup>).

SITE NO.	SITE NAME	SITE TYPE	DESCRIPTION	COMMENTS
1	Stockyard Site	Shell midden	Estuarine and beach shells. Stone artefacts (including backed blades)	Very similar in appearance to Wombah 1 midden
2	Barri Point	Shell midden good food place	Midden located on sand dune behind rocky platform. Beach, rocky platform, estuarine shellfish. Stone artefacts and bone	Important scientifically frequently used fishing place
3	Angourie Point	Shell midden		Recorded on N.P.W.S. file but not relocated.
4	Angourie Headland	Shell midden	Beach & rocky platform shell fish. No stone artefacts	
5	Water tower site	Shell midden	Estuarine shellfish, stone artefacts sparsely scattered over 30 x 30m	
6	Ryan's Lagoon	Shell midden	Shell midden (beach species) and stone artefacts sparsely scattered over area 100 x 100	
7	Seasonal camp	Recent camping place	Beach dunes and Ridge; springs nearby	Also a good food place; away from town camps
8	Southern Beach	Good food place	Another important fishing beach	
9	Wooloweyah Beach	Good food place	Estuarine beach	Winter camps and food collecting places
10	Freshwater springs	Good food place	Beach cliff	Water source
11	Angourie Pt.	Good food place	Fishing spot	

## DISCUSSION

The view that there is information of value to the archaeologist still to be collected from the Aborigines living on the N.S.W. coast might be challenged on a number of grounds. Such arguments are based largely on a feeling that contact between Aborigines and others has been going on for so long in this area that little useful information remains, a consequence of the rapid dispossession of tribal lands that the Aborigines in eastern Australia experienced soon after initial contact. The growing incidence of Aborigines passing on information to field workers that may have come from E.I.S. reports, academic papers and monographs on Australian prehistory seems to further substantiate this position. Most archaeologists seem willing, however, to accept the results of ethnoarchaeological study from Arnhem Land, Cape York, or central Australia. In anthropology too, there seems to be an over-emphasis on data obtained in these areas, rather than in the more densely settled regions of south-eastern Australia in the current debate on the concept of "tribe" and the question of land ownership among Aborigines (although see Calley (1959) for discussion of clan organization of the Bandjalang of the N.S.W. north coast).

Three arguments serve to dispel these objections. Firstly modern hunter-gatherers felt worthy of ethnoarchaeological study are not likely to be indicative of the wide range of hunter-gatherers, horticulturalists and others that inhabited Australia and elsewhere before European colonization. Usually, they have survived only because their land was not considered valuable (Schrire 1980). One might question whether Aboriginal culture in particular areas can be extrapolated to the rest of the continent. This would perhaps apply more to the use of ethnographic analogy and parallel than generalizing from ethnoarchaeology.

Second, a number of the major ethnoarchaeological studies have been carried out with groups living a far from traditional lifestyle. Hayden's (1977) work on stone tool technology was undertaken with Aborigines who did not use stone tools until asked to do so by the researcher though they had done so in the past. Meehan's (1982) study of the Anbara was carried out after the people had returned to the bush after living at Maningrida for 10-15 years. Gould's (1970) study of the small group living in the bush and who had very limited contact with whites could be argued not to have these draw-backs. But these people were exceptions anyway, in that they had little contact with most of the Aborigines living in the area (Gould, 1970: 25). Further, Reynolds' (1981) study of the Aboriginal side of inter-racial contact makes it clear that actual physical contact was not necessary for Aboriginal society to be altered by Europeans; goods and ideas travelled well ahead of the European colonists.

Of course the major part of the problem concerns the use of ethnoarchaeological data. No one would suggest that we can simply use a "best fit" method, dumping the archaeology and ethnography together to get a composite picture of Aboriginal prehistory. Ethnoarchaeological data can be used in two ways: a) as an hypothesis-erecting device, the propositions of which can be tested against the archaeological data, or b) to develop law-like principles of human behaviour that can be accepted as applying in prehistoric times (see Yellen 1978:2) for two other possible methods). Accepting these two approaches, the arguments outlined above are not so damaging to the northern and central Australian examples; but, equally, the study of Aborigines living in coastal N.S.W. has a validity as well. We may be able to draw testable hypotheses and principles from work carried out with them.

During the Yamba survey the recording of the archaeological sites was undertaken separately from recording and visiting areas of significance to local Aborigines. When maps of these features were compared, however, it was found that there was a close correlation between the position of the shell middens, and Good Food Places and Recent Camping Places of present-day local Aborigines (see figure 1). In areas which were of no particular significance to the Aborigines no archaeological sites were encountered. For each of the six shell middens there was an attendant Good Food-getting Place or Recent Camping Place. We do not think this association of features fortuitous and feel it invites comparison with examples from the Northern Territory. Jones' (1980) comment about Anbara activities is apt. "What makes a particular location good for a dinner-time camp, or a food-processing site today will also be good tomorrow, and therefore the type of discard across the landscape is not at random but is quite tightly structured" (Jones, 1980:159). The Yamba evidence mirrors this very tight discard structure observed by Jones. We will now examine the reasons why we think this occurs.

We do not suggest that this represents the complete round of activities. Indeed we chose only to highlight those areas where archaeological survey was undertaken. There are many other Good Food and Camping Places in the general area. Undoubtedly, some of these could be used in a way analogous to Meehan's (1982:163-5) observations of the Anbara after an extremely wet season. After destruction of the most favoured food resources in the area, the Anbara merely exploited less-valued areas for different resources. A more comprehensive field study might reveal a far more complicated picture of exploitation than that presented here. But we think that the conclusions we present here still stand.

North Coast Aboriginal communities have, at the moment, a low socio-economic position (i.e. they are poor, though we use this term in the non-technical sense of the word - cf. Gale, 1977: 326-7). This is due in the main to the high level of unemployment amongst them. Thus, there is little money flowing through the Aboriginal communities and money that is available is not necessarily spent first on European food. There are often other necessities of higher priority. As a result there is a desire to supplement the diet by catching fish, collecting vegetable foods and shellfish, and killing the occasional kangaroo or ant-eater. These foods they either eat or sell as food or bait to others. Due to the usurpation of hunting lands by European pastoralists, this need to supplement the European-based diet would have been present in the past, probably almost immediately after European contact. It may have been exacerbated in the more recent past by mechanization of jobs previously performed by unskilled labour (e.g. sugar cane cutting).

It may be reasonably asked how this makes the Yamba Aborigines any different from any other group of poor. We think there are two important points that go some way in both answering this question and explaining the relationship between prehistoric archaeological sites and present-day food-getting and camping places. First, a census and genealogy collected during discussion with local Aboriginal informants indicated that many of them have Yaygir ancestry. The Yaygir tribe occupied the Yamba area at the time of contact. Many of them have affinal kin ties with the Bandjalang and Gumbaynggir tribes to the north and south of their territory respectively. However, they also espouse a definite affiliation and identity as a particular socio-linguistic group. It is

true that long contact with potentially dominating outsiders, first their Aboriginal neighbours, then Europeans, has meant a continuous process of transformation of Yaygir identity, involving the sharing of language, resources and beliefs with other groups, both Black and White. Yet throughout, these people have maintained a separate and distinctive Aboriginality as Yaygir people (Figure 2).

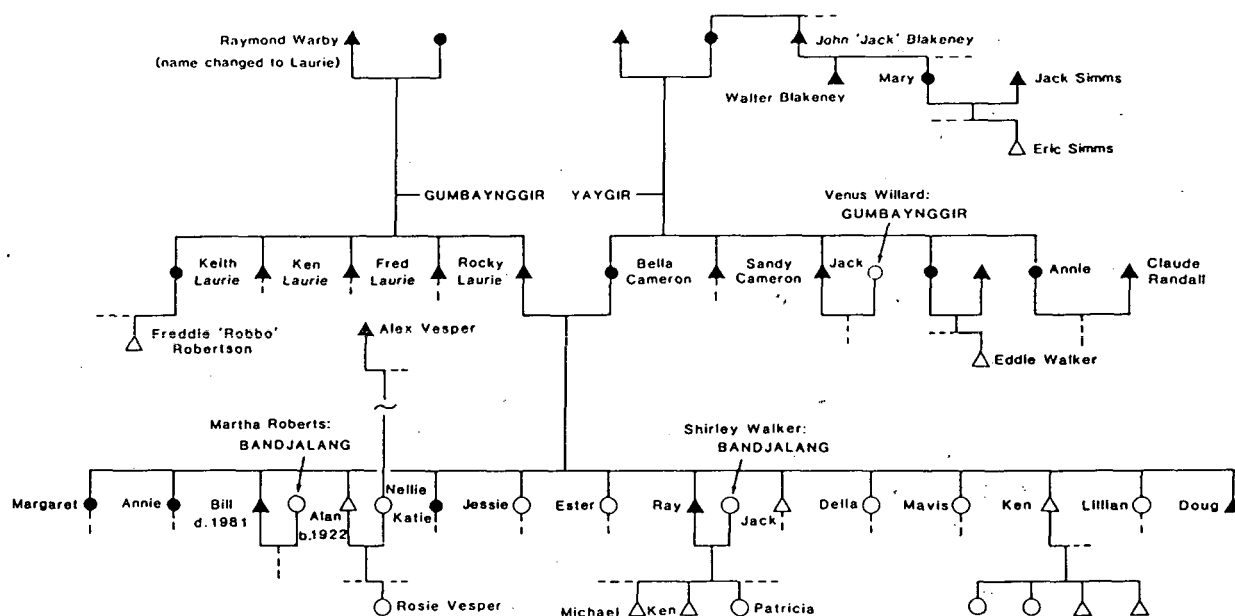

Figure 2. Genealogy of the Laurie family, Yamba. Living members are represented by unshaded symbols.

Second, we know that at the time of European contact the Yaygir, or some of them at least, were semi-sedentary. When Matthew Flinders visited the area in 1799 he found an inhabited "village" of large circular huts (Ryan 1964:171). The huts suggest a relatively high degree of sedentism. Food resources must have been within close walking distance of the "village". Coleman (1982:7) has argued cogently that such villages were more than merely seasonal aggregations to exploit seasonally abundant resources.

It is apparent, then, that the Yaygir people now living in Yamba, have a demonstrable relationship of descent and residence with those Aborigines living in the area at the time of initial European settlement. With this and their use of traditional foods in mind, it is not surprising that areas exploited by Aborigines before European contact continue to be used by their descendants, though not necessarily using traditional Aboriginal techniques.

Although the middens are close to the Good Food-getting and Camping places, the activities carried out by present day Aborigines at those places are not primarily associated with shellfish collecting. They are either hunting, fishing or camping activities. In the case of Barri Point, the area is an excellent fishing place. In the case of the Stockyard midden, swans' eggs can be collected abundantly from the area.

There are two explanations that could account for this discrepancy between the prehistoric shell middens and the use to which these areas are now put by local Aborigines. 1) It could represent a change in the use to which these areas were put economically. Coleman (1982:8-9) suggests that there was a major change in subsistence strategies in the region ca. 2,000 years ago. However most of the sites considered in this paper are likely to post-date this period and are thus a reflection of the newer strategy, as seen at contact. 2) It could mean that the shell middens are indicators of an area used for some other purpose. The shell middens were not formed in those areas because the Aborigines were primarily interested in the shellfish there; rather they were carrying out some other activity and eating shellfish there was an associated activity.

There is a variety of evidence to support this second contention. Firstly, the shell middens themselves contain evidence of other types of food. Both the Stockyard and Barri Point middens have bone from other animals in them (excavation would provide a clearer picture). They also contain stone tools more than likely associated with the procurement of vegetable or vertebrate animal food. The Stockyard midden contains backed blades (Bondi points), which appear to be associated with large game hunting elsewhere in N.S.W. (McBryde 1976). The only shellfish types which are severely limited in their geographical distribution are rocky platform types. Estuarine species can be collected from anywhere along the river banks and lagoon and pipis can be collected from anywhere along the beaches. This might suggest that there is no need for large shell middens to accumulate anywhere except behind rocky platforms. Why then the large Stockyard midden?

Even where a specific association between the middens and collection of shellfish might be expected, namely the rocky platforms, we find that the two middens on them are composed of a variety of shellfish types. The Barri Point midden contains lots of pipis and some estuarine shellfish. The Angourie Point midden is composed almost completely of pipi shell. Thus, the collection of rocky platform shellfish species at either of these two sites does not seem to have been the primary reason for their location at these places.

This discussion rests on the association of only six archaeological sites and places of significance to present-day Aborigines in the Yamba area of N.S.W. We recognize that this is a small sample. Interestingly, however, in an area ca 200km south of Yamba this same relationship occurs between archaeological sites unknown to local Aborigines and areas they now exploit for fish and shellfish. The New South Wales National Parks and Wildlife Service Sites of Significance Survey team recorded an area significant to Aborigines near Scotts Head on the mid-north coast of N.S.W. This site, known as "Ngumbar Campsite", was supposed traditionally to have been camped on by a group of Aborigines from the Ngumbar tribe. Local Aborigines still go to this area today as it is known to them as an area of good fishing. Thus, it could be classified as both an Ancestral Camping Place and a Good Food Place. This information was obtained from an initiate of the Gumbaynggir tribe (Kelly and Donovan 1976). When this recording was made, no attendant archaeological features were reported, nor were any listed in the N.P.W.S. register. When one of us (L.G.) carried out a survey in the area subsequent to the collection of this information, three shell middens were located, two of them quite extensive and in a stratified context.

Most archaeological sites do not give any indication of the relative contribution of plant foods, but even where only animal meat can be quantified we find that shellfish contributed less than half the meat represented by bones and shellfish at even the largest and densest of middens. For Stuarts Point midden, on the N.S.W. mid-north coast, Callaghan (1980:96) calculated that all shellfish species contributed 245.94 kg of meat while fish and mammals contributed over 334kg. For Clybucca, also on the mid-north coast, Callaghan calculated that shellfish provided 91.6 kg of meat, while fish and mammals contributed 103.6kg. Barz (1982:14) makes a similar observation concerning a midden located on the Tweed River estuary. Here, although the shellfish are the most obvious remains, the fish remains are actually the most important in terms of the quantity of food contributed to the diet.

Some shell middens seem to be oriented purely to the exploitation of shellfish. Examples of these types of middens are those found at Ballina (Bailey, 1975) and Wombah (McBryde, 1974). This orientation towards shellfish is adduced from the apparent lack of any other food remains apart from shellfish. Forgetting for the moment the taphonomic problems, particularly that of differential preservation of bone, it can be argued that even if such middens were primarily located for exploitation of shellfish, they could only represent a minor element of the annual diet quantity-wise. Bailey (1975: 56) has calculated that the oysters in one of the Ballina middens comprise 97% of the meat weight represented by bone and shell in the midden. This oyster meat would have been sufficient to supply 100 people with 50% of their calorific requirements for only 14 days a year over the period the midden was occupied.

Even if shellfish were the most important element in a diet, location of the middens can still relate to other factors. Sullivan (1976, 1980) has shown that a number of criteria other than shellfish availability control midden location on the N.S.W. coast. Access to water, stone sources and desired landform to camp on seemed to influence their location. O'Connor (1980:100-12) argues forcefully that the location of the Stockyard midden site on Hunter Island can be best interpreted as taking advantage of as large a number of resources as possible. That is, the site is located at an optimal location for a number of resources so that all these resources may be utilized as desired or required. As the site is located in the centre of the island anyway it is unlikely that it was located primarily to exploit shellfish.

The most detailed ethnographic account of Aboriginal subsistence strategies is that by Meehan of the Anbara in Arnhem Land (1977;1982). In analysing data on the relative contribution of various foods to the Anbara diet, Meehan found that at no time during the year did shellfish contribute more than 9% of the food consumed. This was an important contribution, because it carried them through lean times when other food was scarce (Meehan 1977:516-23). However, it also means that the resulting shell middens are a reflection of less than 10% of the food consumed at such sites. This emphasizes the arguments presented above. However, while we have argued that camp site location is related to resources other than shellfish, Meehan (1977:523) comments that for the Anbara "proximity to shell beds was a major consideration in the location of base and dinner time camps". Whether there is some major difference in the variables considered in making decisions about camp site location in northern and south-eastern Australia remains to be more fully investigated. There is no reason to suppose, however, that shellfish did not serve the same role of staple food in coastal south-eastern Australia as they do in northern Australia (Bowdler 1981).

## SOME FURTHER CONSIDERATIONS

Another use of the Yamba data concerns archaeological survey strategies. Such strategies can be a highly sophisticated means of sampling an area for archaeological sites. They may be based on statistical and environmental considerations, but an opportunistic "grab-bag" strategy is more generally employed particularly on preliminary surveys related to E.I.S. work. This strategy entails the location of areas of supposed archaeological visibility on aerial photographs and by a vehicle-assisted examination of the area. Then a more detailed examination on foot is undertaken of these areas of reasonably high archaeological visibility. This is generally employed because dense vegetation can make penetration of areas difficult and locating of archaeological relics near-impossible. Time considerations may also play their part in the selection of this strategy. It is generally hoped that there will be a cleared area representative of each of the environments in the survey area. If this is not the case a few transects are made of the zones that do not possess any areas of reasonable archaeological visibility, for the sake of saying at least it was checked. The information presented in this paper suggests that information from Aboriginal informants about places they go to collect food and fish, and camp to "get away from it all", may allow some refining of the above survey method. In addition to employing the "grab-bag" method, examination of present-day Aboriginal food-getting areas and camping places may be a means of gaining some definable, controllable limits on areas that might otherwise only be checked by transect. It is at least as suitable as this "hit or miss" tactic.

Although in the Yamba case we have demonstrated a continuity of land tenure and thereby argued that exploitation of resources is an expression of this continuity, another explanation could be proffered. This is that the places that the Yamba Aborigines visit to collect food are simply the best places to go. That is, utilization has been determined by environmental rather than cultural considerations. This may be so, but little alters the usefulness of the study as an ethnoarchaeological observation as it still contains information of use to the archaeologist in understanding site location in areas where Aborigines are no longer present. This means that the observations might be generalized and extended to areas where similar environmental conditions pertain, but no Aboriginal informants are available. Clearly an interesting situation emerges where archaeological evidence shows that the prehistoric inhabitants were not exploiting resources in such a way at a site location. Study of Aborigines living on reserves in Queensland would allow us to develop this aspect because there we have people utilizing "traditional" foods, but in areas that were not necessarily their traditional ranges, because they have been moved.

Chase (1981:23-4) has criticized the attitude of those researchers who have studied outback Aborigines because they see them as possessing the last remaining vestiges of true Aboriginality. He suggests that this tends to invite comparison between "real" Aborigines (those living in outback northern and central Australia) and town/urban Aborigines, who are seen to be trying to cash in on the "real" Aborigines' land claims and hard-won concessions. Langton (1981: 17) has further argued that this dichotomy between tribal Aborigines and town/urban Aborigines has led to a situation where town/urban Aborigines are considered to be cultureless, or at best possessing a "culture of poverty". Chase and Langton both show convincingly that a distinct Aboriginal culture does

exist in cities, towns and missions elsewhere in Australia. They possess either traditional forms of culture (such as seen by Chase at the Lockhart River mission in Queensland) or entirely new forms that can only be seen as a distinctly Aboriginal adaptation to new circumstances.

Amongst the Yaygir people of Yamba little information about increase sites and very little about totemic affiliations persists. However this is not so in the case of knowledge of hunting, fishing and collecting practices and places where these can be carried out. Indeed the main reasons for the success of Aborigines in this area in adapting to the many changes brought about since the coming of Europeans, appear to be gradual, and have not cut off the strong ties that people have with the land. There is a continuity of land/resource utilization which may extend back as far as ca.3,000 years. Observations such as these have significant implications for the granting of land rights to Aboriginal people who are living in southern parts of the continent, not just those in the Northern Territory. The Yamba example emphasizes that a distinctly Aboriginal culture can be seen to exist in this group of "town" Aborigines. We are not suggesting that unless some demonstration of continuity with "traditional" Aboriginal culture is made, no distinctive Aboriginal culture exists (see Langton (1981) for criticisms of this argument). We are saying that in the case of the Yamba Aborigines, this continuity is a demonstration of this distinctive Aboriginal culture. This is another example of the "tribal-rural-urban" triangle and "real" versus "town" Aboriginal dichotomy being shown to be a false distinction between these various groups of Aborigines.

Finally we think this situation of Aborigines being to some degree dependent on locally-available natural resources is also an opportunity to broaden the scope of E.I.S. work. It seems that such work must take into account Aboriginal interests related to other than sacred, religious and mythological sites (recognizing that these are not mutually exclusive). The Yamba people would be adversely affected by any development in their area which deprived them of access to these good food places and camping places. Natural resources play an important part in their economy. We can perhaps see the use of these traditional food sources in terms of the concept of staple foods as discussed by Bowdler (1981) and Meehan (1975). The "traditional" foods exploited by the Aborigines at Yamba do not necessarily contribute the greatest proportion of food to their diet, either in terms of weight or calories. They are however, seasonally, dependable resources that can be called on as needed. Hinderance of access to these resources would cause considerable hardship for the community, in the way that destruction of sites of religious significance that held a more emotional attachment would also be inimical to the interests of Aboriginal people.

We have attempted to show that there is some information of value to archaeologists to be obtained from ethnographic studies of the Aborigines of the N.S.W. coast, and possibly elsewhere in the settled areas of southern Australia. At the very least it might serve some predictive value for E.I.S. work. However, more detailed study is likely to reveal information of greater import than simply that of site location. It may be that further studies will be useful in advancing discussion about, for instance, optimal foraging strategies and continuity in belief systems relating to use/ownership of land and resources, questions of interest to anthropologists and archaeologists alike.

## REFERENCES

- Bailey, G.N. 1975 The Role of Molluscs in Coastal Economics: Results of Midden Analysis in Australia. Journal of Archaeological Science 2: 45-62.
- Barz, K. 1982 Terranora 19: An Estuarine Midden at Tweed Heads, New South Wales. In S. Bowdler (Ed), Coastal Archaeology in Eastern Australia pp. 11-15. Australian National University Press, Canberra.
- Biernoff, D. 1978 Safe and Dangerous Places. In L.R. Hiatt (ed) Australian Aboriginal Concepts pp. 93-105. Australian Institute of Aboriginal Studies, Canberra.
- Bowdler, S. 1981 Hunters in the Highlands: Aboriginal Adaptations in the Eastern Australian Highlands. Archaeology in Oceania 16: 99-111.
- Callaghan, M. 1980 An Analysis of the Molluscan Remains from the Macleay River Midden Sites. Unpublished B.A. (Hons) thesis, University of New England, Armidale, N.S.W.
- Chase, A. 1981 Empty Vessels and Loud Noises: Views about Aboriginality Today. Social Alternatives 2(2): 23-7.
- Coleman, J. 1982 A New Look at the North Coast: Fish Traps and "Villages". In S. Bowdler (Ed), Coastal Archaeology in Eastern Australia, pp. 1-10. Australian National University Press, Canberra.
- Creamer, H. 1975 From the Cultural "Bind" to a Solution. Australian Archaeology 2:17-22.
- Gale, F. 1977 Aboriginal Values in Relation to Poverty in Adelaide. In R.M. Berndt (ed) Aborigines and Change pp. 326-31. Australian Institute of Aboriginal Studies, Canberra.
- Gould, R.A. 1970 Yiwarra: Foragers of the Australian Desert. Charles Scribners and Sons, New York.
- Hayden, B. 1977 Stone Tool Functions in the Western Desert. In R.V.S. Wright (Ed), Stone Tools as Cultural Markers pp. 178-88. Australian Institute of Aboriginal Studies, Canberra.
- Jones, R. 1980 Different Strokes for Different Folks: Sites, Scale and Strategy. In I. Johnson (Ed), Holier Than Thou pp. 153-172. Australian National University, Canberra.
- Kelly, R. 1975 From the "Keeparra" to the "Cultural Bind." Australian Archaeology 2:13-6.
- Kelly, R. 1979 Why we Bother: Information Gathered in Aboriginal Site Recording in New South Wales. In J.R. McKinlay and K.L. Jones (Eds), Archaeological Resource Management in Australia and Oceania, pp.78-82. N. Z. Historic Places Trust, Wellington.

- Kelly, R. and T. Donovan 1976 Survey of Sites in the Nambucca Area. Unpublished report, National Parks and Wildlife Service, N.S.W.
- Lampert, R.J. 1981 Review of I. McBryde (Ed) "Records of Times Past". Archaeology in Oceania 16:71.
- Langton, M. 1981 Urbanizing Aborigines: The Social Scientists' Great Deception. Social Alternatives 2(2): 16-22.
- McBryde, I. 1974 Aboriginal Prehistory in New England. Sydney University Press, London.
- McBryde, I. 1976 Subsistence Patterns in New England Prehistory. Queensland Museum Occasional Papers in Anthropology 6: 48-68.
- McBryde, I. (Ed) 1978 Records of Times Past. Australian Institute of Aboriginal Studies, Canberra.
- Meehan, B. 1977 Man Does Not Live by Calories Alone: The Role of shellfish in a coastal cuisine. In J. Allen, J. Golson and R. Jones (Eds) Sunda and Sahul pp. 493-531. Academic Press, London.
- Meehan, B. 1982 Shell Bed to Shell Midden. Australian Institute of Aboriginal Studies, Canberra.
- O'Connell, J. and K. Hawkes 1981 Alyawarra Plant Use and Optimal Foraging Theory. In B. Winterhalder and A.R. Smith (Eds), Hunter-Gatherer Foraging Strategies: Ethnographic and Archaeological Analysis, pp.99-125. The University of Chicago Press, Chicago.
- O'Connor, S. 1980 Bringing it All Back Home: An Interpretation of the Stockyard Midden, Hunter Island. Unpublished B.A. (Hons) thesis, The University of New England, Armidale, N.S.W.
- Radcliffe-Brown, A.R. 1929 Notes on Totemism in Eastern Australia. Journal of the Royal Anthropological Institute 59:399-415.
- Reynolds, H. 1981 The Other Side of the Frontier. James Cook University Press, Townsville.
- Ryan, J. 1964 The Land of Ulitarra. Dept. of Continuing Education, University of New England, Armidale, N.S.W.
- Schrire, C. 1980 An Inquiry into the Evolutionary Status and Apparent Identity of San Hunter-gatherers. Human Ecology 8(1):9-32.
- Sullivan, M. 1976 Archaeological Occupation Site Locations on the South Coast of New South Wales. Archaeology and Physical Anthropology in Oceania 11:56-69.
- Sullivan, M. 1980 Specific Generalizations. In I. Johnson (Ed), Holier Than Thou pp. 143-6. A.N.U. Canberra.
- Yellen, J.E. 1978 Archaeological Approaches to the Present. Academic Press, London.